

SUPERIOR • DESIGN



About us

Nichiyu is a pioneering developer of electric forklifts in Japan. Since introducing the country's first electric forklift in 1937, Nichiyu has continued to introduce a variety of innovative electric forklift solutions. We take pride in our ability to provide customer-focused products and exceptional service.

Committed to comprehensive service

We maintain highly trained service staff in every country in which we sell our products. Should you require regular periodic maintenance or emergency repair, simply contact us for fast and efficient on-site service. We take pride in our commitment to first-rate support and unmatched customer service.

All specifications have been determined according to manufacturer's terms and conditions. Specifications are subject to change without notice in the interests of product improvement.

NICHIYU
ELECTRIC FORKLIFT

www.nichiyuforklift.com.sg
©2024 by MLAP. All Rights Reserved. All registered trademarks are the property of their respective owners. Printed in Singapore.
FNCY0021-02(06/2024)



ELECTRIC FORKLIFTTRUCK
**COUNTER BALANCED
THREE-WHEELER**
FBT13-20



ELECTRIC COUNTER BALANCED THREE-WHEELER FBT13-20

SUPERIOR • FEATURES

Nichiyu Three-wheeler

Featuring exceptional comfort and advanced functions, this new design encompasses all the elements necessary to maximise overall safety, durability, and the versatility to handle any work environment.

Choose from 6 varied models to accommodate a wide range of applications.



The standard series ensures easy turning and manoeuvre in narrow aisles of warehouses.

1.3t **FBT13P** 1.5t **FBT15P** 1.6t **FBT16P** 1.8t **FBT18P** 2.0t **FBT20PN**

The PB Series accommodates a super-high capacity 730 Ah battery for longer running times.

2.0t **FBT20PBN**



An Appealing Design with Well-rounded Features



Featuring the SICOS-AC Multifunctional Centralized Control System

An AC motor powers the traveling and hydraulic operations. This control system ensures comprehensive and centralized AC control for smooth and powerful operation.

Excellent Space-Saving Design with 1510 mm Turning Radius

With a minimum turning radius of only 1510 mm (Model FBT15P), the Nichiyu Three-wheeler is ideal for material handling in limited space. The double rear wheels add extra stability in turns.

Lighter Weight Body

The reduced body weight contributes to improved handling while maintaining good stability. In addition, it is more eco-friendly thanks to its reduced energy consumption.



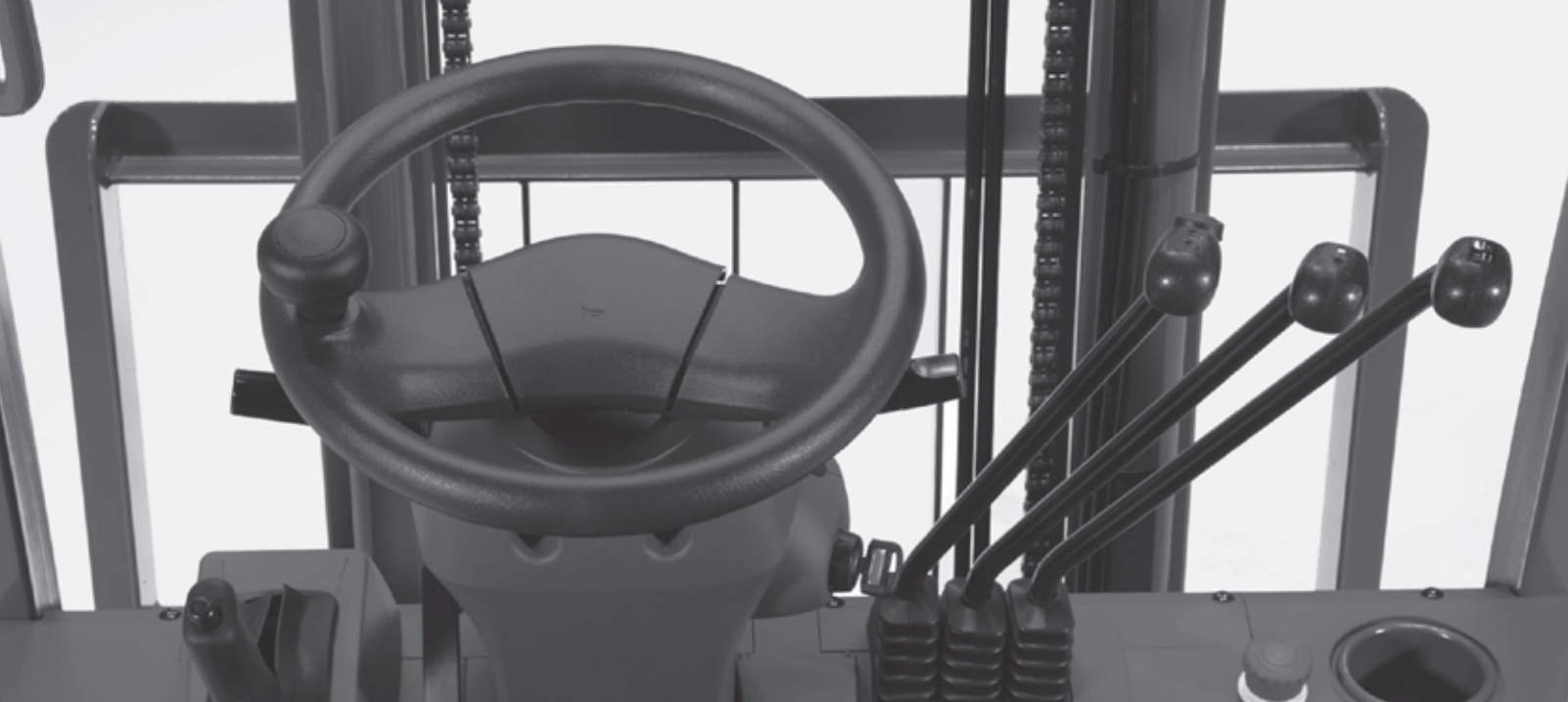

Standard Advanced Features



Electric Power Steering

The power steering motor is centrally controlled by the SICOS-AC system. This simple and economical approach reduces power consumption by two-thirds compared with conventional hydraulic power steering.



Fork Soft Landing Feature

A soft-landing mechanism has been adopted to slow the speed of the forks as they descend to the floor. This feature significantly reduces both shock and impact noise (when unladen).



Multifunction Display

The display reveals the battery state, vehicle speed, and other aspects of vehicle status at a glance. An innovative load indicator is also provided as standard equipment.



Seat Suspension

The comfortable and secure seat suspension contributes to stable operation. In addition, it is equipped with an emergency locking retractor mechanism for the seat belt to enhance operator safety.



Spacious Legroom

Legroom has been increased by 55 mm compared with previous models (some models excluded). A floor mat is also provided as standard for increased operator comfort.



Combination Tail Lamps

The large, highly visible tail lamps clearly indicate braking and turning as well as reverse operation.

Comfort

Comfortable operation contributes to increased efficiency.

Grip Assist with Integrated Horn

A new right rear handgrip is provided to ensure greater operator stability during rearward travel. The integrated yellow horn button allows for easier alerting of near by personnel during rearward operations.

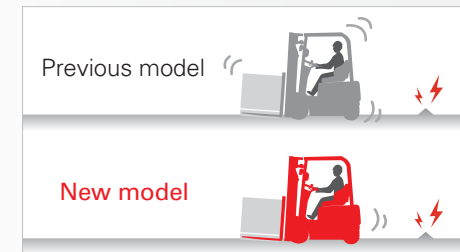

Pitching Reduction System

We have incorporated a Pitching Reduction System to relieve the operator of uncomfortable lurching motion during travel.



Improved Forward Visibility

The display panel has been moved to the right to increase operator visibility of the fork tips. This innovation helps to make driving even more stress-free.



Increased Head Clearance

The new head guard is designed for increased head clearance.



Increased Mast Backward Tilt Angle

We've increased the maximum tilt angle to 7.5°, an increase of a full 1.50° over the previous model. This feature contributes to improved cargo security during travel.



Easier Boarding

We've included a new wide and low step as well as a larger handgrip for use when boarding.



Optional Integral Sidsifter

An integral sidsifter is available as an option. This innovation contributes to higher operation efficiency without reducing load capacity.

SUPERIOR • TECHNOLOGY

**Still think you need an engine?
Think again!**

A dependable truck that can be operated indoors or outdoors, in almost any weather

**Advanced technologies
ensure greater operational
safety and security**



IPX4 Enclosure Rating Level

The IPX4 enclosure rating indicates a splash-proof design that allows for safe work out of doors, even in the rain. This model is resistant to the detrimental effects of water spray from any direction.



When the battery cover is opened, any falling water is safely caught in a drainage tray.



The controller is securely housed in the left side of the frame.



Waterproof floor mat



Lever boots



Safety Cruise

Even if the accelerator or brake is released on an upslope, the truck will not roll down quickly but instead, roll down in a safe and controlled speed.



Parking Brake Alert

An audible and visual alarm alerts an operator who leaves the vehicle without setting the parking brake. This alarm can be triggered even when the key is turned off.

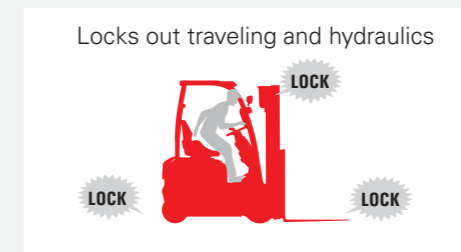

Operation Interlock System

The operation interlock system (OIS) ensures that all traveling, hydraulic, and tilt operations are automatically locked out about two seconds after the operator leaves the driver's seat.



Emergency Stop Button

This emergency shutoff switch is provided as a red emergency button located on the instrument panel.

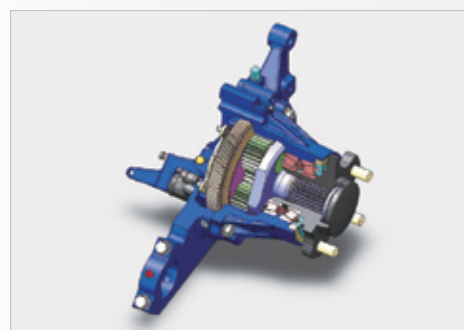

Wet Disc Brakes

Unaffected by dust and moisture, the wet disc brakes provide powerful braking force.



The PB Series: Designed for long hours operation.

The super-high-capacity 730 Ah battery and long wheelbase contribute to lengthy operating time and highly stable traveling.



- Battery side loading specification
- Cold storage specification
- Rust resistant specification

Optional Accessories

Contributing to a more efficient work environment



1 Headguard roof



2 Front window

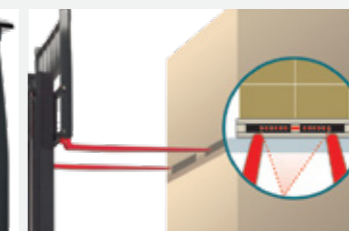

3 Laser pointer



4 LED headlamp

5 Rearview mirror

6 Room mirror

7 Chime

8 Worklight

9 Backup lamp

10 Revolving light

Actual Capacities and Mast Specifications (with and without integral sideshifter)

Mast Type	Lift height <H3>	Mast specification (mm)				Capacities (Kg) At LC=500																
		Free lift <H2>		Mast lowered height <H1>	Tile angle	FBT13P			FBT15P			FBT16P			FBT18P			FBT20PN		FBT20PBN		
		9/10/13/15/16/18	20	9/10/13/15/16/18/20	α/β	Pneumatic	No Puncture	Cushion	Pneumatic	No Puncture	Cushion	Pneumatic	No Puncture	Cushion	Pneumatic	No Puncture	Cushion	No Puncture	Cushion	No Puncture	Cushion	
Two-stage full-visibility (Simplex) mast	300	3000	115	120	1975	5/7.5	1300	1300	1300	1500	1500	1500	1600	1600	1600	1800	1800	1800	2000	2000	2000	2000
	330	3300	115	120	2125	5/7.5	1300	1300	1300	1500	1500	1500	1570	1570	1600	1800	1800	1800	2000	2000	2000	2000
	350	3500	115	120	2225	5/7.5	1300	1300	1300	1500	1500	1500	1550	1550	1570	1770	1770	1800	2000	2000	2000	2000
	370	3700	115	120	2325	5/7.5	1270	1270	1300	1500	1500	1500	1530	1530	1550	1730	1750	1770	2000	2000	2000	2000
	400	4000	115	120	2525	5/7.5	1200	1230	1270	1400	1450	1500	1450	1470	1530	1630	1670	1730	2000	2000	2000	2000
	450	4500	115	120	2770	3/6	1130	1150	1230	1250	1350	1400	1270	1370	1430	1400	1600	1650	1800	1800	1830	1830
	500	5000	115	120	3035	3/6	900	1070	1170	1050	1250	1300	1070	1270	1330	1150	1450	1550	1600	1600	1630	1630
Two-stage full-free (Duplex) mast	300PFL	3000	960	970	1975	5/6	1300	1300	1300	1500	1500	1500	1600	1600	1600	1800	1800	1800	2000	2000	2000	2000
	330PFL	3300	1110	1125	2125	5/6	1270	1270	1270	1500	1500	1500	1550	1550	1570	1800	1800	1800	2000	2000	2000	2000
	350PFL	3500	1210	1225	2225	5/6	1270	1270	1270	1500	1500	1500	1530	1530	1550	1770	1770	1800	2000	2000	2000	2000
	370PFL	3700	1310	1325	2325	5/6	1270	1270	1270	1500	1500	1500	1530	1530	1550	1730	1750	1770	2000	2000	2000	2000
	400PFL	4000	1510	1525	2525	5/6	1200	1230	1250	-	-	-	1430	1470	1530	1630	1670	1730	2000	2000	2000	2000
Three-stage full-free (Triplex) mast	370M	3700	760	775	1775	5/6	1230	1270	1270	-	-	-	1470	1530	1530	1630	1750	1750	1950	1950	1950	1950
	400M	4000	860	875	1875	5/6	1170	1230	1230	-	-	-	1400	1470	1470	1570	1670	1670	1930	1930	1930	1930
	430M	4300	960	975	1975	3/6	1130	1170	1170	1250	1400	1400	1330	1430	1430	1470	1630	1630	1850	1850	1850	1870
	450M	4500	1030	1045	2045	3/3	1070	1150	1150	1200	1350	1350	1270	1370	1370	1350	1570	1570	1800	1800	1800	1830
	470M	4700	1110	1125	2125	3/6	1050	1130	1130	1150	1300	1300	1200	1330	1330	1270	1530	1530	1700	1700	1730	1750
	500M	5000	1210	1225	2225	3/6	900	1070	1070	1000	1250	1250	1030	1270	1270	1100	1470	1470	1600	1600	1600	1630
	550M	5500	1400	1415	2415	1.5/5	700	950	950	770	1100	1100	800	1130	1130	850	1150	1200	1170	1300	1170	1300
	600M	6000	1580	1595	2595	1.5/5	500	670	800	550	700	850	570	730	870	600	750	900	770	1000	700	1000
	650M	6500	1820	1835	2835	1.5/4	370	450	550	400	470	570	430	500	600	450	530	630	550	650	550	650
	700M	7000	2020	2035	3035	1.5/4	250	300	350	270	330	370	300	350	400	330	370	430	400	450	400	450

* Mast Raised Height <H₄> : Lift Height <H₃> + 1015mm for FBT13/15/16/18 + 1000mm for FBT20

Aisle Width

	Pallet size	Mast type	FBT13P	FBT15P	FBT16P	FBT18P	FBT20PN	FBT20PBN
Front overhang (mm)		Two-stage Mast	375	375	375	375	415	415
		Two-stage Mast w/ISF	395	395	395	395	430	430
		Third-stage Mast	400	400	400	400	420	420
		Third-stage Mast w/ISF	425	425	425	425	430	430
Practical 90° turning aisle width* ³⁾ (mm)	W1100 x L1100	Two-stage Mast	1930	1960	1990	2000	2020	2050
		Two-stage Mast w/ISF	1940	1970	2000	2010	2030	2060
		Third-stage Mast	1950	1970	2000	2010	2030	2060
		Third-stage Mast w/ISF	1960	1980	2010	2020	2030	2060
Practical 90° stacking aisle width* ³⁾ (mm)	W1100 x L1100	Two-stage Mast	3185	3285	3380	3435	3505	3585
		Two-stage Mast w/ISF	3205	3305	3400	3455	3520	3600
		Third-stage Mast	3210	3310	3405	3460	3510	3590
		Third-stage Mast w/ISF	3235	3335	3430	3485	3520	3600

*3) 200mm clearance included

Standard Specifications

Item		Summary		Unit		NICHYU						
Type	1 Model					FBT13P	FBT15P	FBT16P	FBT18P	FBT20PN	FBT20PBN	
Type	2 Rated capacity		Q	kg		1300	1500	1600	1800	2000	2000	
	3 Load center		C	mm		500	500	500	500	500	500	
	4 Operator type	Stand-on / Seated				Seated	Seated	Seated	Seated	Seated	Seated	
	5 Lift height		H ₃	mm		3000	3000	3000	3000	3000	3000	
Dimensions	6 Free lift		H ₂	mm		115	115	115	115	120	120	
	7 Tilt angle	For-/Back-ward < F:Down/Up >	α/β	deg.		< Mast > 5 / 7.5	< Mast > 5 / 7.5	< Mast > 5 / 7.5	< Mast > 5 / 7.5	< Mast > 5 / 7.5	< Mast > 5 / 7.5	
	8 Carriage					Class II A	Class II A	Class II A	Class II A	Class II A	Class II A	
	9 Fork	Dimensions (L / W / T)	ℓ / w / t	mm		1070 / 100 / 35	1070 / 100 / 35	1070 / 100 / 35	1070 / 100 / 35	1070 / 122 / 40	1070 / 122 / 40	
	10 Spread (Max / Min)		B ₃ / B ₄	mm		920 / 240	920 / 240	920 / 240	920 / 240	1000 / 245	1000 / 245	
	11 Length	Overall length	L ₁	mm		2855	2955	3050	3105	3175	3255	
		to fork face	L ₂	mm		1785	1885	1980	2035	2105	2185	
	13 Width	Overall width	B	mm		1090	1090	1090	1090	1090	1090	
		Mast lowered	H ₁	mm		1975	1975	1975	1975	1975	1975	
	15 Height	Mast extended	H ₄	mm		4015	4015	4015	4015	4000	4000	
		Overhead guard	H ₅ ₁	mm		2050	2050	2050	2050	2050	2050	
	17 Overhang	Front overhang	F	mm		375	375	375	375	415	415	
	18 Min. turning radius		R	mm		1410	1510	1605	1660	1690	1770	
	19 Practical 90° turning aisle ^{*1)}	1100 x 1100 Pallet			mm		1930	1960	1990	2000	2020	2050
	20 Practical 90° stacking aisle ^{*1)}	1100 x 1100 Pallet	A _s	mm			3185	3285	3380	3435	3505	3585
Performance	21 Travel speed	Laden / Unladen		km/h		15.0 / 16.5	15.0 / 16.5	14.5 / 16.0	14.5 / 16.0	14.0 / 15.5	14.0 / 15.5	
	22 Lifting speed	Laden / Unladen		mm/s		400 / 610	380 / 610	360 / 610	360 / 610	300 / 500	300 / 500	
	23 Lowering speed	Laden / Unladen		mm/s		550/500	550/500	550/500	550/500	550/500	550/500	
	24 Max. drawbar pull	3min. rating, 1.5km/h and over		N		7530	7390	6910	7530	7550	7550	
	25 Max. gradeability	3min. rating, 1.5km/h and over		%		20/20	18/20	15/20	15/20	14/17	14/17	
Mass	26 Service weight	w/o battery (6.3)		kg		2075	2105	2080	2220	2595	2285	
	27 Axle loading	Laden (Front / Rear)		kg		3460/465	3735/455	3820/445	4155/515	4650/595	4815/590	
		Unladen (Front / Rear)		kg		1230/1395	1245/1445	1235/1430	1245/1625	1355/1890	1615/1790	
Chassis	29 Tyres : Number	Front / Rear (X = Drive)				2X / 2	2X / 2	2X / 2	2X / 2	2X / 2	2X / 2	
	30 Tyres	Front		mm		18x7-8-14PR	18x7-8-14PR	18x7-8-16PR	18x7-8-16PR	18x7-8 (N.P.) ^{*2)}	18x7-8 (N.P.) ^{*2)}	
		Rear		mm		15x4 1/2-8-12PR	15x4 1/2-8-12PR	15x4 1/2-8-12PR	16x6-8-10PR	16x6-8-10PR	16x6-8-10PR	
	32 Wheelbase		L ₃	mm		1220	1320	1415	1415	1415	1525	
		Front		mm		920	920	920	920	920	920	
	34 Tread	Rear		mm		250	250	250	230	230	230	
		Min.	m1	mm		85	85	85	85	85	85	
	36 Ground clearance	Middle of wheelbase	m2	mm		85	85	85	85	85	85	
		Service brake	Mech. / Hydr. / Electr. / Pneum.				Hydr.	Hydr.	Hydr.	Hydr.	Hydr.	Hydr.
	38 Parking brake	Foot / Hand / Deadman					Hand	Hand	Hand	Hand	Hand	
Motors	39 Battery	Type				BS/JIS	BS/JIS	BS/JIS	BS/JIS	BS/JIS	BS/JIS	
		Volts / Ampere hrs (5HR)		V/Ah			48 / 320	48 / 350	48 / 350	48 / 390	48 / 390	48 / 730
		Mass (with case)		kg			595	595	595	650	650	1120
	42 Drive motor	60min. rating		kw			2 x 4.5	2 x 4.5	2 x 4.5	2 x 4.5	2 x 4.5	2 x 4.5
		control					Inverter	Inverter	Inverter	Inverter	Inverter	Inverter
	44 Hydraulic motor	5min. rating		kw			9.5	9.5	9.5	9.5	9.5	9.5
		control					Inverter	Inverter	Inverter	Inverter	Inverter	Inverter
	46 Power steering motor	60min. rating		kw			0.3	0.3	0.3	0.6	0.6	0.6
		control					Chopper	Chopper	Chopper	Chopper	Chopper	Chopper
	48	Type (Built-in / Stationary)					Stationary	Stationary	Stationary	Stationary	Stationary	Stationary
49 Charger	Input		φ/V			3 / 200	3 / 200	3 / 200	3 / 200	3 / 200	3 / 200	
	Capacity		kVA			4.7	6.5	6.5	6.5	6.5	11.0	
51 Operating pressure	for Attachments		MPa			13.7	13.7	15.7	15.7	18.1	18.1	

FBT20PBN

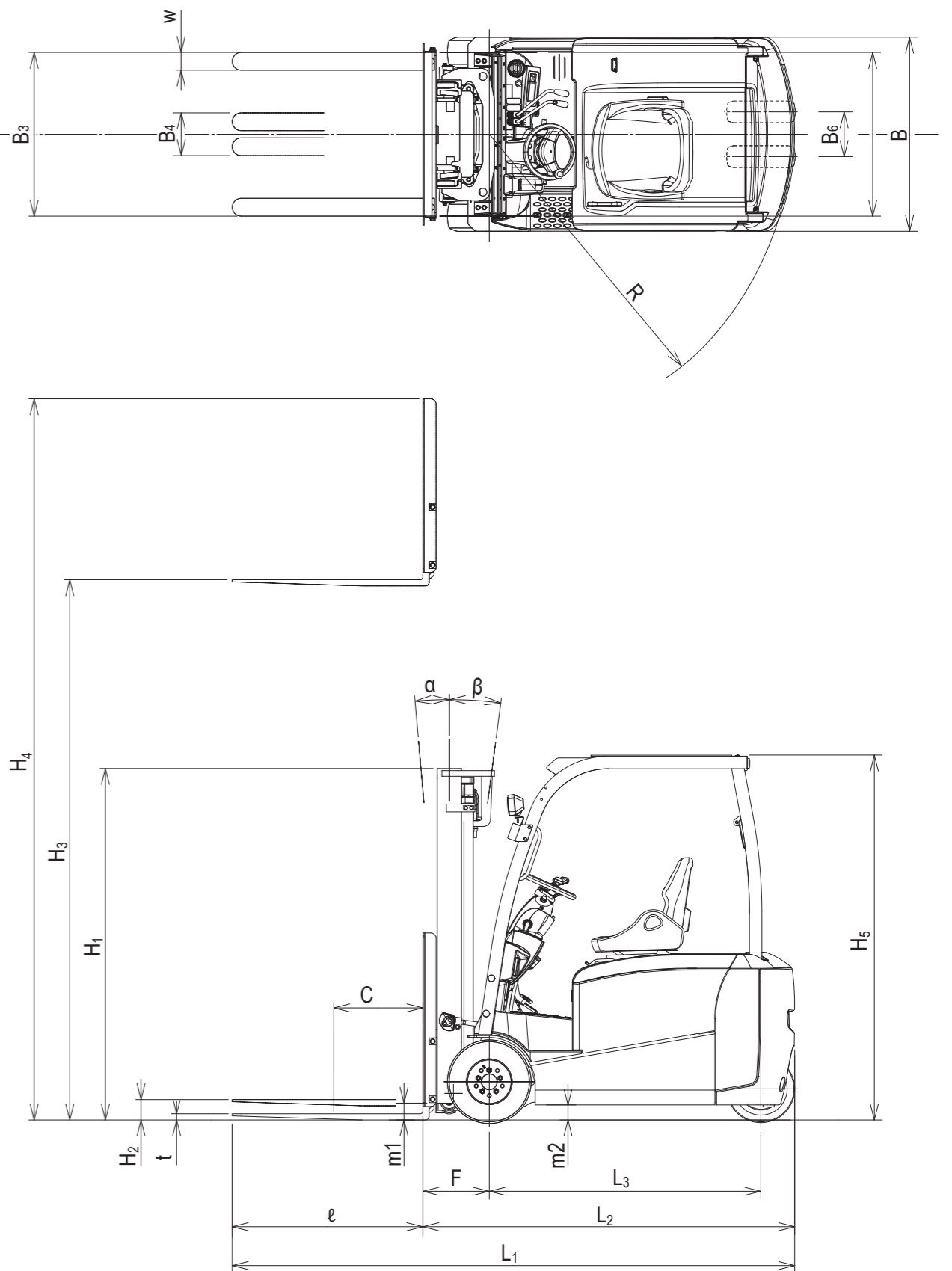

Above specifications are based on the standard truck with 3 meters simplex mast.
 They may vary by mast type & lifting height, tyres, battery capacity and/or warming up condition.
 *1) 200mm clearance included
 *2) N.P. : No puncture tyre